

Supplementary instructions

Air cooling - MINITRAC 31

Active air cooling system for radiation-based sensors

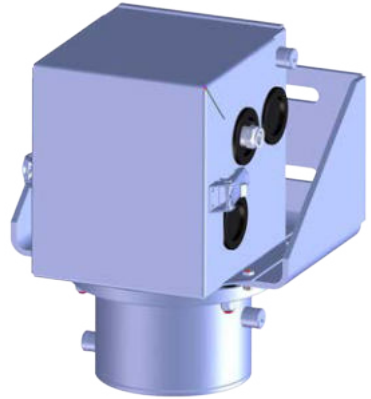

Document ID: 50337



VEGA

Contents

1 Product description	
1.1 Configuration.....	3
2 Mounting	
3 Replacement parts	
3.1 Available spare parts - air cooling.....	13
4 Supplement	
4.1 Technical data	14
4.2 Dimensions	15

1 Product description

1.1 Configuration

The active air cooling system is suitable for radiation-based sensors of series MINITRAC 31.

The air cooling system consists of several modules.

Housing cooling box (A) The housing cooling box is placed above the instrument housing and enables cooling of the instrument housing.

Housing cooling (B) The cooling module for the housing is also cooled by the housing cooling box (A).

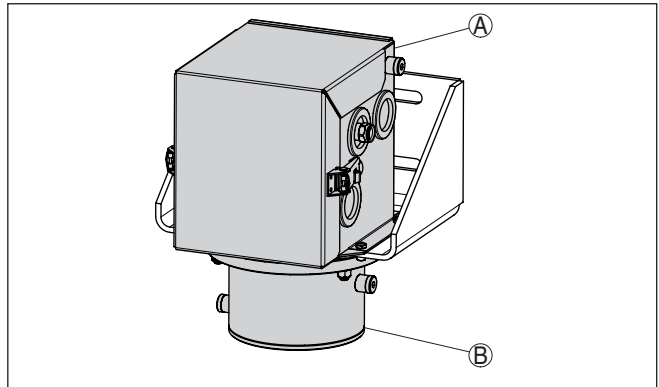

Fig. 1: Active air cooling system with fastening bracket

- A Housing cooling box
- B Housing cooling

Scope of delivery

The following parts belong to the scope of delivery of the air cooling system:

- Housing cooling
- Fastening bracket
- Housing cooling box with detachable lid
- Hexagon socket screw M5 x 14 (6 pieces)
- Spring ring for M5 (6 pieces)
- Eddy current cooler (type FOS 208SS 25 HVE BSP) for housing cooling box
- Isolating sleeve (6 pieces)
- Fixing screw M8 x 35 (2 pieces)
- Fixing screw M8 x 40 (4 pieces)
- Washer for M8 (10 pieces)
- Hexagon nut M8 (4 pieces)
- Blind plug 1/4" (3 pcs.)
- NPT threaded adapter for vortex cooler (optional)



Information:

When the sensor is ordered with cooling, the sensor and the air cooling system are shipped pre-assembled.

If the air cooling system is ordered later, you have to mount it on the sensor yourself.

You can find further information in chapter "*Mounting*".

2 Mounting

Operating instructions

Mounting preparations

Take note of the operating instructions manuals of the corresponding radiation-based sensors and the source holder.



Warning:

During all mounting and dismantling work, the source container must be in switch position "OFF" and secured by a lock.

Carry out all work within the shortest possible time and at the largest possible distance. Provide suitable shielding.

Avoid risk to other persons by taking suitable measures (e.g. safety fence, etc.).

Mounting may only be carried out by authorized, qualified personnel who are monitored for radiation exposure according to local laws or the handling permit. Take note of the specifications in the handling permit. Also take the local conditions into account.



Caution:

The cooling system is used in areas with high temperatures. Therefore, use temperature-resistant cable and install it in such a way that contact with hot components is avoided.

General mounting instructions



Information:

When the sensor is ordered with cooling, the sensor and the air cooling system are shipped pre-assembled.

If the air cooling system is ordered later, you have to mount it on the sensor yourself.

Required tools:

- Fork wrench SW13 mm (2 pieces) - for the housing cooling
- Fork wrench SW19 mm (2 pcs.) - for the connections of the vortex coolers

Take note of the following general mounting instructions:

- First of all, mount the fastening bracket and the housing cooling, and then the sensor
- The small lid of the instrument housing must point to the front after mounting the fastening bracket (x)
- The sensor together with the air cooling system is very heavy. Use a suitable lifting device for mounting, e.g. a hoisting sling

Mount the fastening bracket

1. Place the isolating sleeves (4) between the housing cooling (5) and the fastening bracket (1).

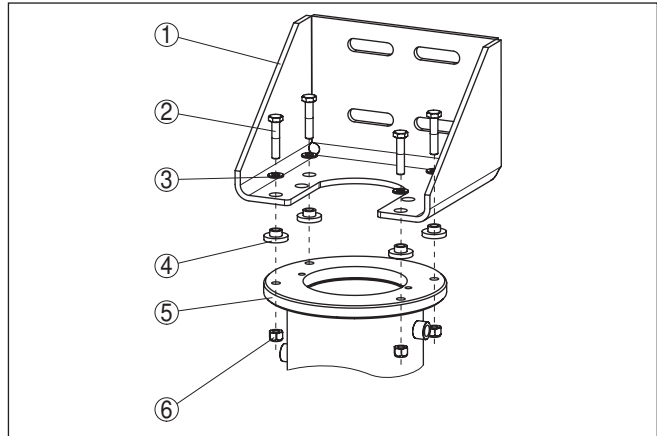

Fig. 2: Housing cooling with mounted sensor

- 1 Fastening bracket
- 2 Hexagon screw M8 (4 pieces)
- 3 Washer for M8 (8 pieces)
- 4 Isolating sleeve (4 pieces)
- 5 Housing cooling
- 6 Hexagon nut M8 (4 pieces)

2. Place the fastening bracket (1) onto the housing cooling (5). Make sure that the coolant connections point in a suitable direction. Rotating the holding bracket later (1) is very difficult.
3. Connect the fastening bracket (1) with the scintillator cooling (5) according to the illustration and tighten the screws (2, 6) with a torque of 15 Nm (11.06 lbf ft).

Mounting the sensor

Mount the housing cooling according to the following assembly drawing:

1. Mount the housing cooling with the fastening bracket in the required position.

The sensor marking is no longer visible when the housing cooling is mounted. You can find the position of the sensor marking according to the following illustration.

Add the sensor marking with a waterproof marker or a permanent, coloured adhesive tape to the outside of the housing cooling.

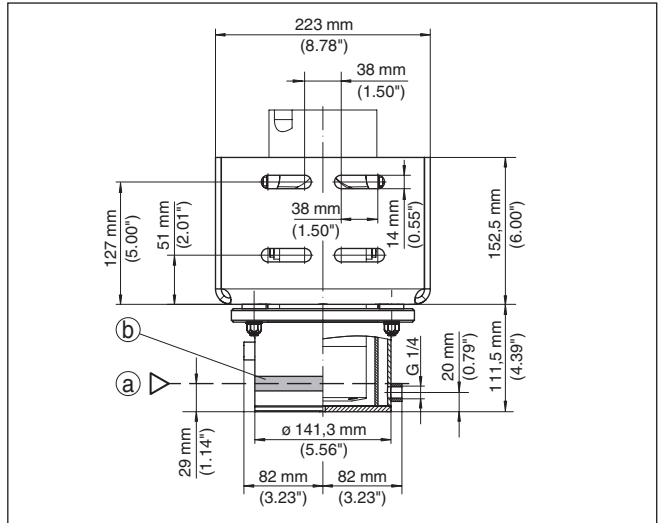

Fig. 3: Position of the sensor marking and drilling template of the fastening bracket

- a Position of the lower measuring range end
- b Sensor marking on the upper edge of the lateral connection nozzle

2. Insert the sensor into the housing cooling.

The small lid of the instrument housing must point to the front after mounting on the fastening bracket (x).

Mount the sensor with the two screws in the respective position.

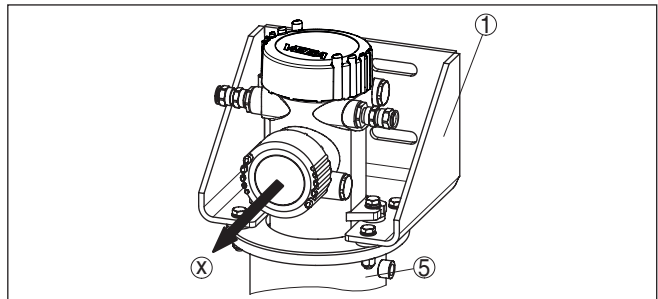

Fig. 4: Mounting direction of the sensor towards the fastening bracket

- 1 Fastening bracket
- 5 Housing cooling
- x Mounting direction of the housing

Mount the sensor according to the following illustration:

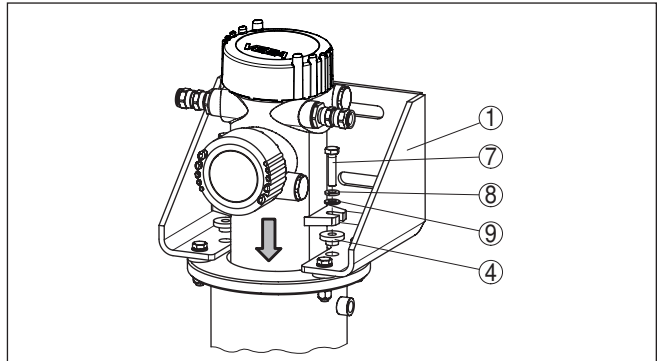

Fig. 5: Mounting the sensor

- 1 Fastening bracket
- 4 Isolating sleeve (2 pieces)
- 7 Hexagon screw M8 (2 pieces)
- 8 Retaining washer for M8 (2 pieces)
- 9 Washer for M8 (2 pieces)

Mounting the housing cooling box

1. Open the fasteners (36) and remove the lid (37) from the lower part of the housing cooling box (38).
2. To make mounting easier, screw the cable glands of the sensor out of the instrument housing.
3. Place the lower part of the housing cooling box (38) on the fastening bracket (1).
4. Insert the 6 hexagon socket screws (39) from below through the mounting bracket (1) and tighten the screws with a torque of 4.5 Nm (3.3 lbf ft).

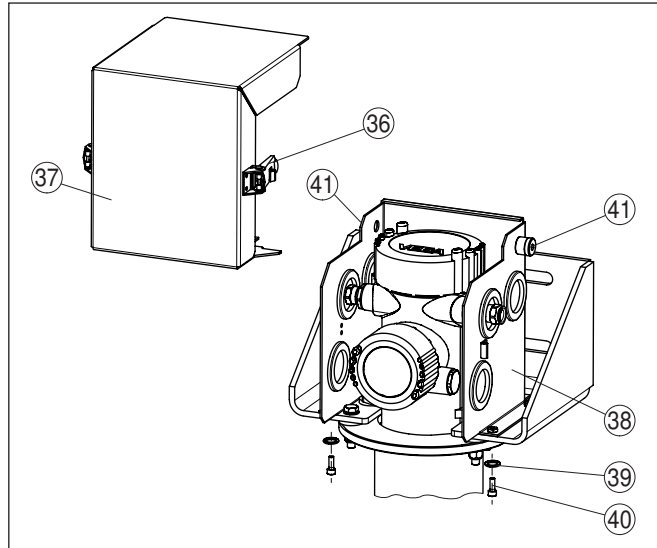

Fig. 6: Mounting the housing cooling box

36 Fasteners with safety latch

37 Lid of the housing cooling box

38 Lower part of the housing cooling box

39 Spring ring for M5 (6 pieces)

40 Hexagon socket screw M5 x 14 (6 pieces)

41 Connection opening for vortex cooler (type FOS 208SS 25 HVE BSP)

Electrical connection

1. Open the fasteners (36) and remove the lid from the housing cooling box (37).
2. Determine which cable gland you need for connection of the sensor.
3. Pierce a small hole with a sharp tool (e.g. pricking awl, scriber, etc.) in the center through the respective rubber diaphragms (42).
Do not use a knife or similar for puncturing

If you have accidentally pierced the wrong diaphragm, you can simply exchange the rubber diaphragms. If you have pierced a diaphragm too much, you can seal it with self-adhesive fabric tape.

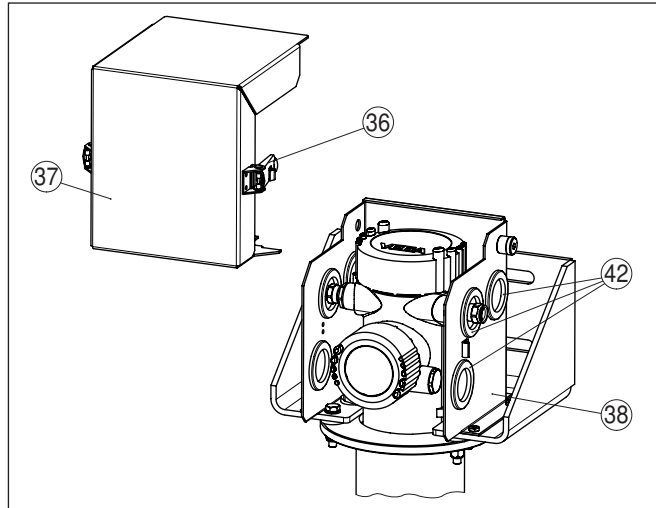

Fig. 7: Preparations for electrical connection

- 36 Fasteners with safety latch
- 37 Lid of the housing cooling box
- 38 Lower part of the housing cooling box
- 42 Rubber diaphragm

4. Insert the cable gland into the resulting opening and screw it tightly to the sensor housing.
Make sure that the rubber diaphragm encircles the cable gland completely so that not too much cooling air can escape.
5. Connect the sensor to voltage supply. Keep in mind the information in the operating instructions of the corresponding sensor or in the wiring diagram on the housing lid.



Note:

The cooling system is used in areas with high temperatures. Therefore, use temperature-resistant cable and install it in such a way that contact with hot components is avoided.

6. From the front side, place the lid of the housing cooling box (37) onto the lower part of the housing cooling box (38).

7. Close the two lateral fasteners (36).

Make sure that the fasteners (36) are provided with safety latches against unintentional opening. To open a fastener, you have to press the safety latch.

Connect cooling

The housing cooling box must be connected to the cooling system.

Cooling systems (vortex cooler)

So-called Vortex coolers are proven possibilities for cooling the sensor.

You can connect the cooling air output of the vortex cooler directly to the housing cooling box.

The vortex cooler is part of the scope of delivery. The cooler thus fits perfectly to your air cooling system with respect to size, cooling capacity and throughput.

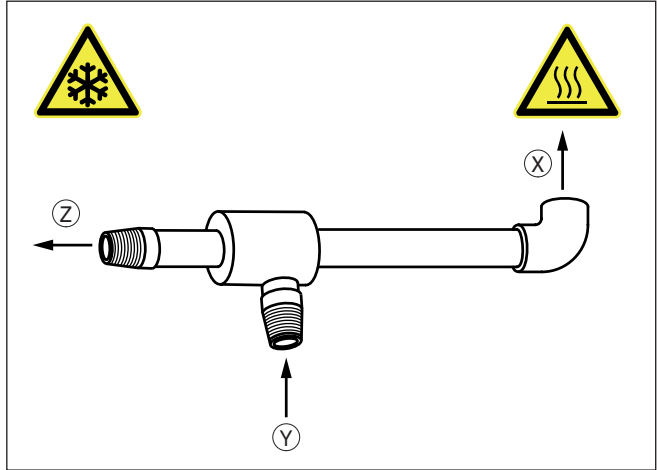

Fig. 8: Eddy current cooler (Vortex cooler)

- x Hot exhaust air
- y Supply air
- z Cooling air



Caution:

The vortex cooler gets very hot during operation. Hot air at approx. 100 °C (212 °F) escapes from the exhaust opening. Furthermore, the cooler or sensor can be very cold on the cold air side. Wear suitable protective clothing and prevent people from touching the cooling system by installing barriers, etc.

Make sure that the exhaust airstream can escape safely into the open. Make sure that no heat-sensitive components or cables are in the exhaust airstream.

If you want to direct the exhaust airstream in another direction, you have to use standard, angled metal fittings with ¼" screw connection.

1. The housing cooling box has two connection openings with ¼" connection.

Close the free openings with a respective bling plug.

2. The two lateral opening on the housing cooling have no function. Close the openings with the attached blind plugs to avoid penetration of dirt and moisture.

3. Connect the vortex cooler.

The vortex cooler type FOS 208SS 25 HVE BSP powers the housing cooling box

Screw in the short cooling air output of the vortex cooler and tighten it with a torque of 25 Nm (18.43 lbf ft).

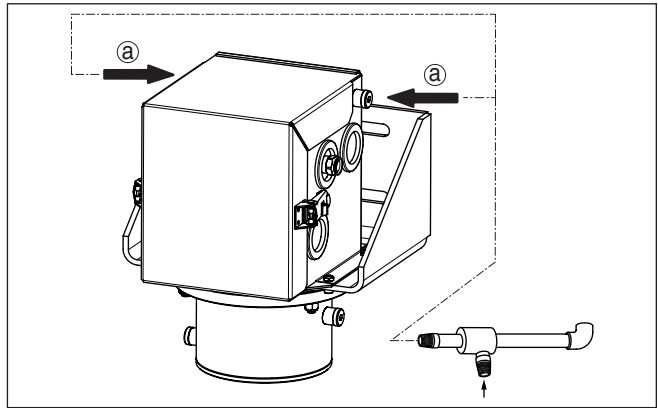

Fig. 9: Connection of the cooling air system (vortex cooler)

a Cooling inlet - Housing cooling box
(vortex cooler type FOS 208SS 25 HVE BSP)
Connection on the left or right possible

For cooling, use clean, water-free compressed air of class 3:3:2 acc. to ISO 8573-1:2010. Make sure that your compressor has enough supply capacity. You can find information on quality, pressure, throughput and temperature of the cooling air in chapter "Technical data".

Make sure that the cooling air inlets do not freeze, e.g. in case of a shutdown.



Caution:

Do not loosen any screws or connections during operation and make sure that the cooling air supply is reliable and interruption-free. Plan the necessary steps for a possible compressed air failure.

We recommend installing a temperature sensor (in the housing cooling box) that triggers an alarm when a critical temperature is reached.



If you want to use the air cooling in an SIL-qualified application, you have to assess the SIL failure rates of the complete air cooling system and the cooling air supply yourself.

Install a protective grid

Take note of the operating instructions manuals of the corresponding radiation-based sensors and the source holder.

When handling radioactive substances, unnecessary radiation exposure must be avoided.

If there are gaps or intervening spaces after mounting, provide protective fences or grids to keep hands away from the dangerous area. Such areas must be marked accordingly.

Install a safety barrier on both sides of the cooling system. A sheet metal cover or an appropriately shaped plastic sheet can also be used.

3 Replacement parts

3.1 Available spare parts - air cooling

Selected components of the cooling are available as replacement parts. The following parts are available:

The stated quantity is the quantity delivered.

Air cooling - vortex coolers

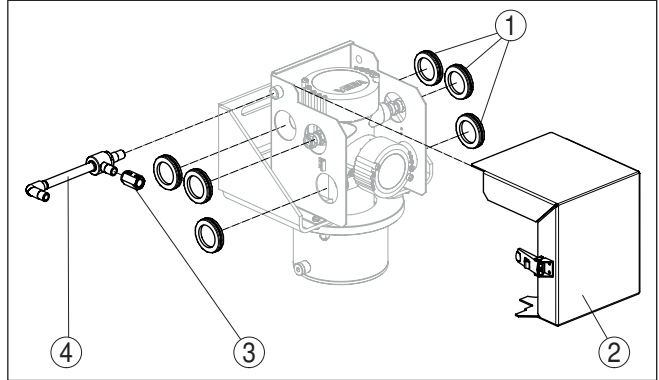

Fig. 10: Spare parts - air cooling MINITRAC

- 1 Rubber diaphragm (2 pcs.)
- 2 Lid of the housing cooling box
- 3 Threaded adapter for vortex cooler ¼ NPT (1 pce.)
- 4 Vortex cooler type FOS 208SS 25 HVE BSP (input for cooling air - housing cooling box)

4 Supplement

4.1 Technical data

General data

Take note of the information in the operating instructions manual of the installed MINITRAC 31 level sensor and the source holder

Material 316L corresponds to 1.4404 or 1.4435

Materials

- Housing cooling 316L
- Housing cooling box 316L

Application temperature See following tables (throughput - coolant)

Weight

- Housing cooling (basic weight) 2.3 kg (5.1 lbs)
- Housing cooling box 3.2 kg (7.1 lbs)
- Fastening bracket 4.8 kg (10.6 lbs)

Torques

- Screws - Sensor mounting (M8) 15 Nm (11.06 lbf ft)
- Nuts - housing cooling (M8) 15 Nm (11.06 lbf ft)
- Threaded fittings - vortex coolers 25 Nm (18.43 lbf ft)

Connection thread of the cooling air inputs ¼" DIN ISO 228 (adapters for NPT fittings are enclosed with respective version)

Throughput - Coolant air

Quality of the compressed air	ISO 8573-1:2010 [3:3:2]
Supply capacity - Compressor ¹⁾	
- Type FOS 208SS 25 HVE BSP	708 L/min (25 SCFM)
Air pressure of the supply air	5 ... 7.9 bar (72 ... 114 psig)
Temperature of the supply air	< +20 ... 25 °C (+68 ... 77 °F)
Ambient temperature	+80 °C (+176 °F)

Approvals

If you use an air cooling system in hazardous areas, make sure that the max. permissible temperatures in the Ex safety instructions are maintained around the sensor. If this is ensured, the sensor can also be used with an air cooling system in hazardous areas.

¹⁾ at 6.9 bar (100 psig)

4.2 Dimensions

Active air cooling system

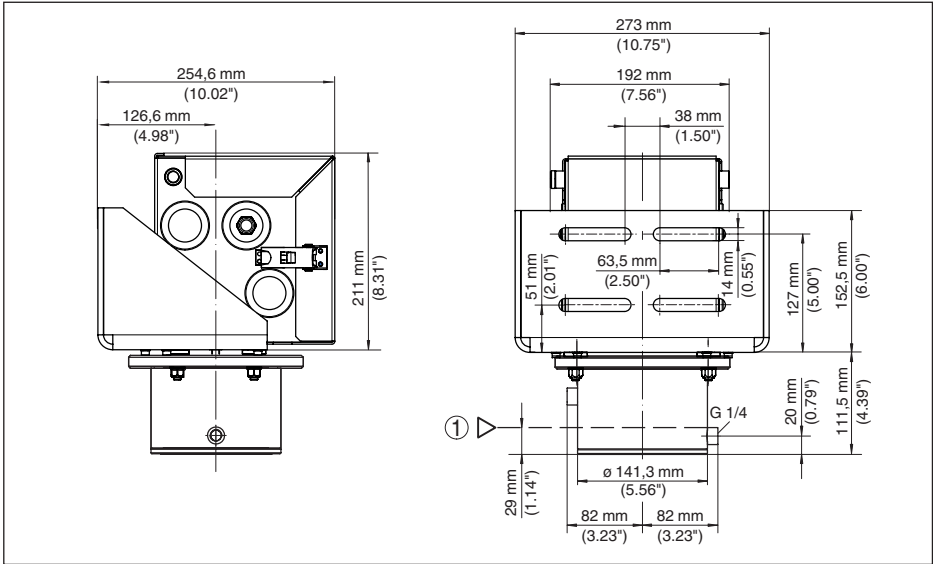

Fig. 11: Active air cooling system with housing cooling box

1 Position of the measuring range end

Printing date:

VEGA

All statements concerning scope of delivery, application, practical use and operating conditions of the sensors and processing systems correspond to the information available at the time of printing.

Subject to change without prior notice

© VEGA Grieshaber KG, Schiltach/Germany 2017



50337-EN-170308

VEGA Grieshaber KG
Am Hohenstein 113
77761 Schiltach
Germany

Phone +49 7836 50-0
Fax +49 7836 50-201
E-mail: info.de@vega.com
www.vega.com